

Floor Heating Central Control System

This multi-device linkage heating system is composed of wired and wireless thermostat, central control box and actuators, usually used in water heating system, through the linkage between various devices to achieve the accurate control of room temperature, it has the characteristics of accurate control and mild energy saving.



1. Working Principles

As turning on the thermostat, the thermal actuator works at first, and the gas boiler and external pump (water mixer) start to work after 120S' delay.

As turning off the thermostats, the heater, external pump and thermal actuator stop working at the same time.

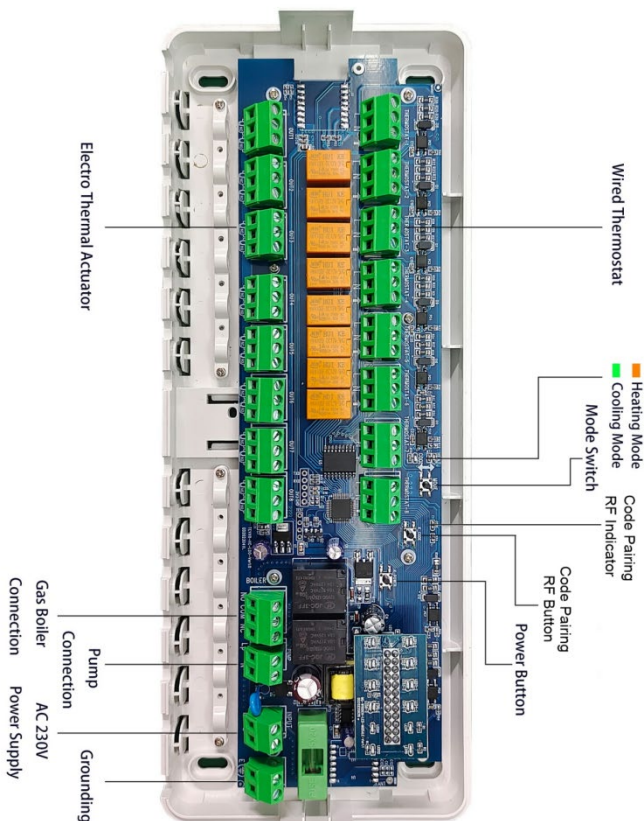

2. Attentions

The output from any one thermostat of all eight thermostats will start the air heater(gas boiler) and external pump.

After the control box starting, the heater and external pump start working after 120S.

The heater works passively and the water pump works with the voltage of AC230V.

3. Parameter:

Power Voltage: 230VAC ±15% 50Hz/60Hz

Max Input Power: 1000W

Communication Type: Wired or wireless

Max Number Thermostat: 8 for heating thermostats

Max Number Actuators: 16

Operation Temperature: -20°C~ 60°C

Heating source, cooling source linkage: 1KW, Delay 120S

4. Indicator description:

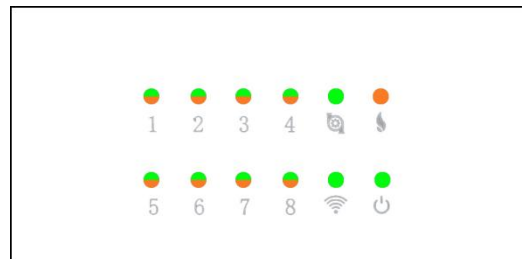

A. No. 1-8 corresponds to an 8 rooms.

a. When the light turns Orange, the actuator valve of the corresponding room will be opened, the heating source will also be activated after 120 seconds, and the room temperature gradually rises until the setting point.

B. Cooling source running indicator, Green lights up to indicate that the cooling source is working.

C. Heating running indicator, Orange lights up to indicate the heating source is working.

D. Power Indicator.

E. App Internet connectivity, including WIFI and zigbee.

5. Heating source:

a. If any of the 8 zones has an output, the heating source is activated.

b. Delay 120S, the heating source start working.

c. The heating source have a NC and a NO 220V 5A output, a 220V 5A ON/OFF output.

d. If the is working properly, the thermostat must be normally closed.

6. Wiring Image:

The control box can realize the control of cooling and heating at the same time or the independent control of the two. At the same time, the control input device is compatible with the cooling & heating four-pipe thermostat, the cooling thermostat, the heating thermostat, and the control output device is compatible with the air damper, electric actuators and valves and other equipment.

1) Power connection

A. Input Voltage: 230VAC 15±15% 50Hz/60Hz

B. Load current: 5A.

NOTE: Please ensure the correct connection of L and N, wrong connection will cause the system to not work properly.

2) Thermostat connection

A. Wired thermostat: the control box can provide 220V power supply to the wired thermostat.

a. Connect the L N terminals of the control box to the L N terminals of the thermostat to provide power for the thermostat.

b. Connect the output terminal of the thermostat to the ↑ terminal of the control box to finish connection.

B. Wireless Thermostat connection:

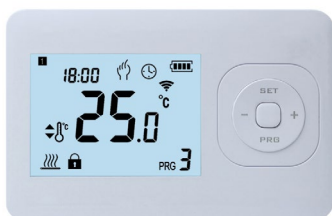

a. Adaptive thermostat: QH-W wireless thermostat

b. Press the power button on the box to turn off it, press and hold the code pairing button on the control box until "CODE" LED will be green and flickering quickly.

c. Turn off sender, and press and hold "SET" button until the screen is lit, then press "PRG" button again **EIGHT(8) times** to set the right zone number from 01-08, then press "PRG" button again to enter the wireless RF code pairing screen.

d. Press "SET" button and waiting

e. Wait for a while, the "CODE" LED on the control box will stop flickering, code pairing done.

f. Repeat the above steps to complete the pairing of other zones.

3) Actuator connection

A. The heating output can be compatible with NC electric actuator, valve and other active switching equipment, it's 220V active connection.

B. One room can connect 2 NC actuators, if you want to connect more, you can connect in parallel.

4) Heating source connection

The control box provides a variety of options for heating source equipment, please choose according to your needs.

A. 220V 5A ON/OFF active output

B. 220V 5A NO voltage free output

C. 220V 5A NC voltage free output

Warning: please ask the professional worker to install them by follow this connecting diagram under no power/ electricity conditions. Please make sure do not put any water, mud and other impurities into the thermostat, otherwise it will cause device damage.

7. WiFi connection:

Before using your WIFI control box for the first time, you must configure the WIFI signal and setting through your smart phone or tablet. This will allow communication between your connected devices.

Step 1. Download your App

For IOS devices, search for Smart Life/Tuya Smart in Apple Store and download.

For Android devices, also can search for Smart Life/Tuya Smart in Google Play and download.



Step 2 Register and log in your account

Open your Smart Life/Tuya Smart, you will get a page of Log In and Sign Up. Press Sign Up and enter your phone no. or email then you can get a verification code. Input your password and confirm to complete your registration. If you have account, please log in.

Step 3 Connect your Wi-Fi signal

On your thermostat receiver

Press "On/off button" and "Code pairing button" together and hold the for five (5) seconds, The **pairing indicator** will be green and flickering.

Then, go back to the home page of your app

Press the + on the upper right corner of the page (Fig 1-1) to add your device. Select "Small Home Application", then click and "Thermostat" (Fig 1-2), then select your network and back to your app to enter the password of your wireless router and confirm, the app will connect automatically(Fig 1-3). This may typically take up to 5~90 seconds to complete(Fig 1-4).

Your room name could be edited when the device is connected.

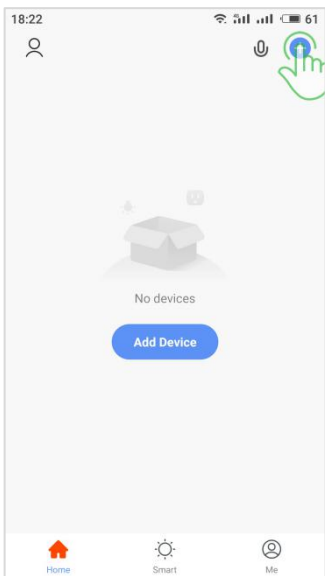

Fig 1-1

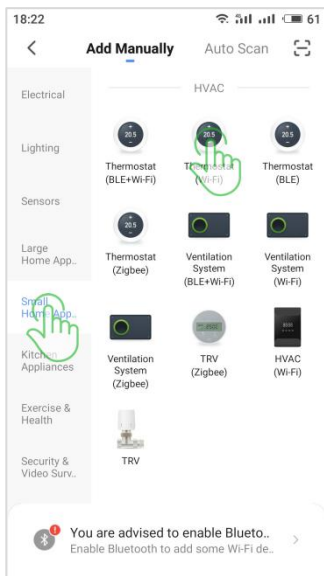

Fig 1-2

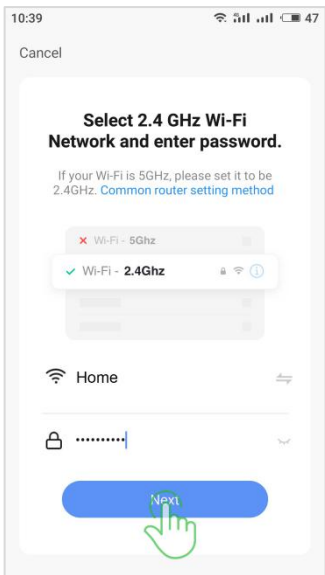

Fig 1-3

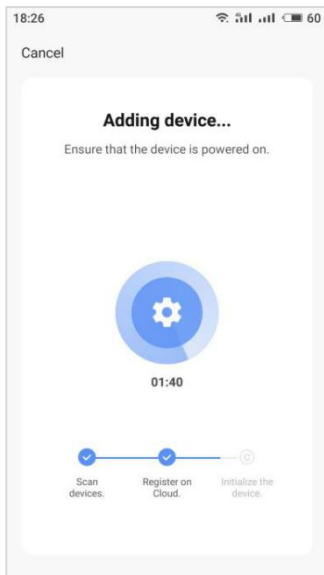

Fig 1-4

wireless thermostat

8. Key Features



- Heating thermostat
- 2xAAA batteries power supply
- Attractive modern styling
- Surface mounting
- CE, ROHS approved
- 433Mhz or 868Mhz RF frequency

9. Technical Data

Power Supply - 2*AAA batteries	Backlight - White
Receiver relay contact - Max 10A	Sensor - NTC 10K
Set Point Range - 5~35°C	Accuracy - ± 0.5°C
Ambient - 0~50°C	Protection Class - IP30
Relative Humidity - 85%	ABS+PC fire retardant plastic

10. Displays & Buttons

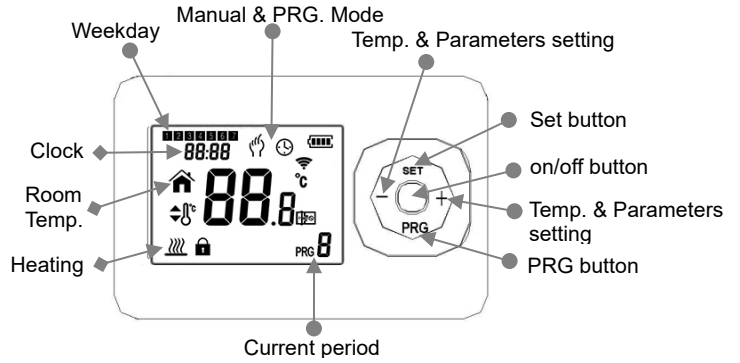

Buttons Function:

on/off button: Press this button for power on/off.

Set button: Clock & Temperature Setting

+ button: for Temp. & Parameters setting increase

- button: for Temp. & Parameters setting decrease

PRG button: Mode select & programmable setting

11. Clock & Temperature Setting

Press and hold SET button for 5s, set the clock (Min-Hour-Weekday) by pressing + and - button, each press of SET button will go to next item setting.

Menu	Description
01	Clock setting- Minute
02	Clock setting- Hour
03	Weekday setting

12. Weekly programming setting

1) Press and hold PRG button for a while to enter program setting.

2) Set the schedule (Weekday-Period-Start time-Temp.) by pressing + and - button, each press of PRG button will go to next item setting.

EXAMPLE:

PERIOD	Period 1	Period 2	Period 3	Period 4
WEEKDAY	WEEKDAY (MONDAY – FRIDAY) (1 2 3 4 5 shows on screen)			
TIME	06: 30	08: 00	18: 00	22: 30
TEMPERATURE	21°C	18°C	21°C	16°C
WEEKDAY 2	WEEKEND (SATURDAY) (6 shows on screen)			
TIME	08: 00	10: 00	18: 00	23: 00
TEMPERATURE	21°C	21°C	21°C	16°C
WEEKDAY 3	WEEKEND (SUNDAY) (7 shows on screen)			
TIME	09: 00	12: 00	19: 00	23: 45
TEMPERATURE	23°C	21°C	16°C	21°C

13. Advanced setting

Turn off the sender, press and hold "SET" button for 5 seconds for coming into the advance setting mode, the screen will display all the related No. & dates, then press "+" or "-" button to set the dates, then press "PRG" to come to the next setting, All of the parameters will be kept in record after press power button after finish setting.

Code	Option	Default	Details
------	--------	---------	---------

		Parameters	
01	Temperature calibration	0°C	-8 °C~8°C
02	Switch differential setting	1°C	0.5~5 °C
03	Floor limiting temperature (For electric heating version only)	35°C	25~60 °C
04	Anti-frozen function	--	Setting Range: 3~10 °C --: Anti-frozen function is turned off
05	Open window detect function (OWD function)	00	'00': close this function '01': open this function
06	OWD Detect Time	05	2-30 min
07	OWD Drop temp. Select (within detect time)	02	2-4 °C
08	OWD Delay time select (Return to previous working status)	30	10-60 min
09	Room Number selection	01	01~08
10	Pairing Code	random code	Please refer to the part 13
11	Reset to factory setting	00	Press "+" or "-" button to '01', and then press "SET" button for 5s, wait until thermostat restart.

14. Wireless RF thermostat connection:

- 1) Turn off the control box, press and hold the RF pairing button for 5 seconds until the indicator flashing, the control box entered the RF pairing mode.
- 2) Turn off the thermostat sender, press and hold "SET" button for 5 seconds for coming into the advance setting mode, the screen will display all the related No. & dates, then press "+" or "-" button to set the dates, then press "PRG" to come to the next setting, All of the parameters will be kept in record after press power button after finish setting.
- 3) After entered the advanced setting, press "PRG" button again **EIGHT(8) times to set the room number**, then press "PRG" again to let the sender enter RF pairing mode, then press "SET" button to send the RF pairing command and waiting.
- 4) After the LED indicator on the control box stopped flashing, the RF pairing mode is finished.
- 5) Repeat the above steps to add more rooms.

15. Installation

Sender

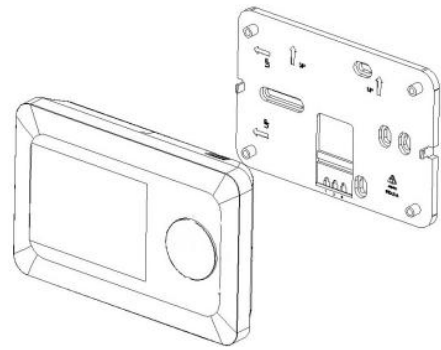

Wall installation

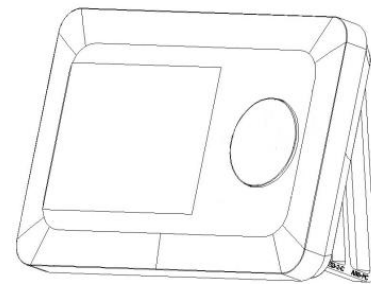

Put on desk

16. Thermal actuator

Thermal actuator is suitable for temperature controlling in home or commercial use by controlling water flow through an underfloor heating system.

Features:

- Used for opening and closing of floor heating water separator, central air conditioner (water system) and small valve.
- Controls water flow through an underfloor heating system, suitable for temperature controlling at home, in hotels, malls, etc.
- Easy installation, 2-wire connection with one valve per loop, M30 * 1.5 installation size.
- Normally closed actuator, automatically turn on when powered up, noiseless and maintenance-free.
- Mine size, lightweight and space-saving. 2W low power consumption, energy-saving.

Specifications:

- Color: Light Grey
- Material: PA66
- Voltage: AC 230V, 50/60Hz
- Power: 2W
- Inrush Current: Max. 550mA
- Type: NC (Normally Closed)
- Installation Size: M30 * 1.5
- Protection Class: IP54
- Storage Temperature: -25°C~60°C

